

Liquid End Installation Instructions

When pumping solutions, make certain that all tubing is securely attached to the fittings. It is recommended that tubing or pipe lines be shielded to prevent possible injury in case of rupture or accidental damage. Always wear protective clothing and face shield when working on or near your metering pump.

Spare Parts: LMI recommends replacing the elastomeric components of the pump on an annual basis. RPM Pro Pacs™ and spare part kits are available from your local LMI Master Stocking Distributor.

Tubing Connections

Your LMI pump will be supplied with one of the following tubing connections. Before installation, all tubing must be cut with a clean square end. Valve and head connections from the factory may be capped. Remove and discard these caps before connecting the tubing.

DO NOT USE CLEAR VINYL TUBING ON THE DISCHARGE SIDE OF THE PUMP.

(Pressure can rupture tubing.)

DO NOT USE PLIERS OR PIPE WRENCH ON COUPLING NUTS OR FITTINGS.

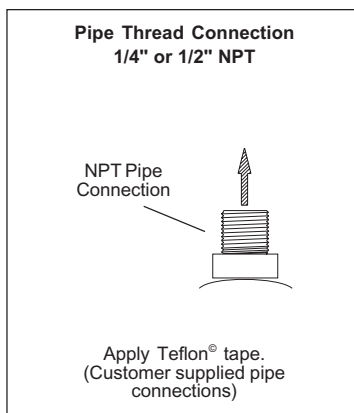
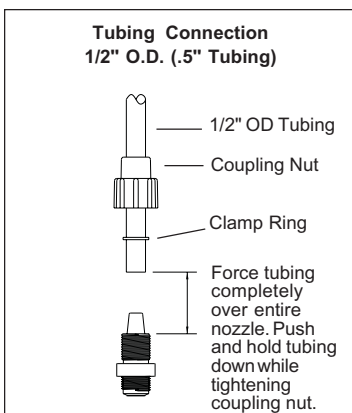
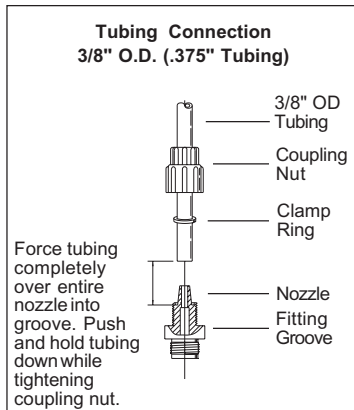
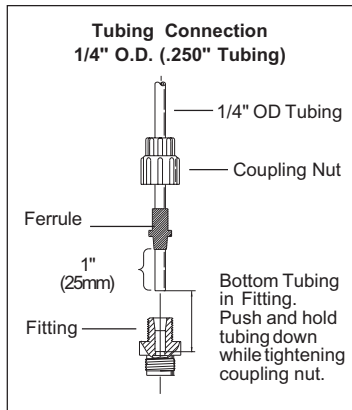

Injection Check Valve and Discharge Tubing Installation

The Injection Check Valve prevents backflow from a treated line. Connect the Injection Check Valve to your "DISCHARGE" (outlet) line. An NPTF fitting or pipe tee with a reducing bushing to 1/2" NPTF will accept the injection check valve. Use Teflon® tape or pipe dope to seal the pipe threads *only*.

When installing the Injection Check Valve, be sure to position it so that the valve enters the bottom of your pipe in a vertical position. Variations left and right within 40° are acceptable (see illustration below).

After cutting an appropriate length of discharge tubing, connect tubing to the injection check valve then back to the discharge side of the pump head valve or discharge fitting. Make sure it does not crimp or come into contact with hot or sharp surfaces (see Tubing Connections).

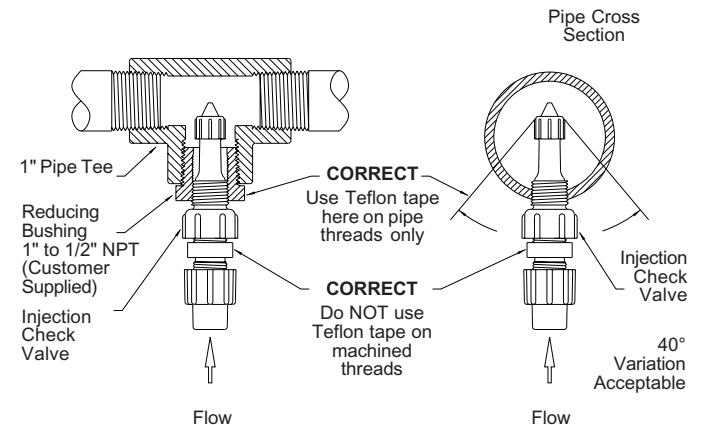

Typical Injection Check Valve Installations



201 Ivyland Road
Ivyland, PA 18974 USA
TEL: 215-293-0401
FAX: 215-293-0445
<http://www.lmipumps.com>



Foot Valve/Suction Tubing Installation

The Foot Valve acts as a check valve to keep the pump primed in suction lift applications.

The foot valve is designed to be submersed in the solution tank or drum and must sit in a vertical position at the bottom. Position approximately 2 inches (50 mm) off the bottom if the tank or drum contains sediment. The ceramic weight, when installed, positions the foot valve in a vertical position.

NOTE: Pump models equipped with high-viscosity liquid ends are not equipped with foot valves. Flooded suction is recommended. A 1/2" NPT connector is included for flooded suction installations.

1. Cut a piece of suction tubing to a length so that the foot valve hangs just above the bottom of the solution container. Maximum recommended vertical suction lift is 5 feet (1.5 m).
2. Attach the foot valve to one end of the suction tubing.
3. Slide the ceramic weight over the tubing end until it contacts the top of the foot valve coupling nut.
4. Place foot valve and tubing into the solution tank. Check that the foot valve is vertical and approximately 2 inches (50 mm) from the bottom of the tank or drum (see illustration). Connect the other end of the tubing to the suction side (bottom side) of the pump head (see Tubing Connections).

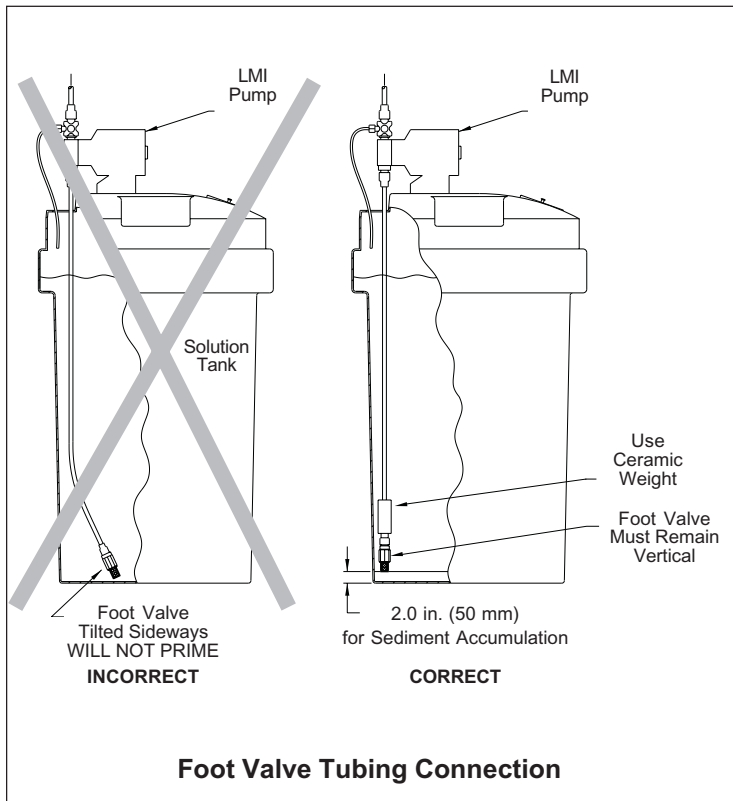

Multi-Function Valve Installation

To install the multi-function valve, remove the yellow screw cap on the top of the pump head and screw in the valve so that it contacts the seal ring. An additional 1/8 – 1/4 turn may be necessary to prevent leakage.

1/4" O.D. tubing connects to the side of the valve and acts as a return line to the solution tank. To ensure priming, this tubing must NOT be submerged in the solution.

This return line tubing must be secured to ensure pumped solution will safely return to supply tank.

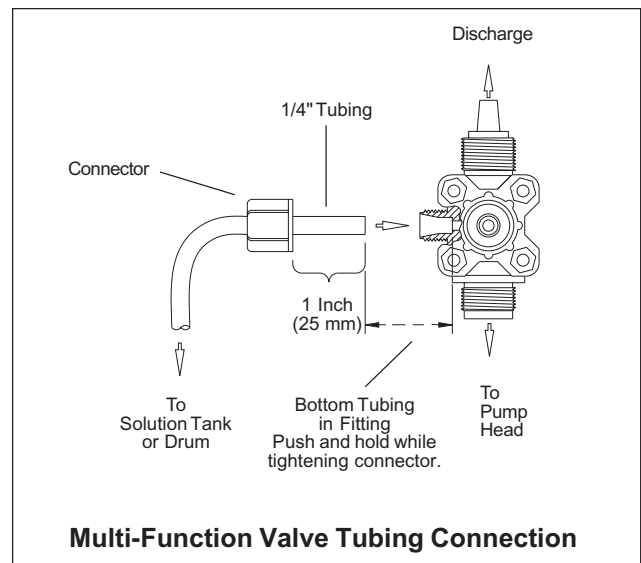

Depressurizing Discharge Line

(pumps equipped with multi-function valves)

It is possible to depressurize the discharge line and pump head without removal of tubing or loosening of fittings.

1. Be sure injection check valve is properly installed and is operating. If a gate valve or globe valve has been installed downstream of injection check valve, it should be closed. Be certain relief tubing from the multi-function valve is connected and run to solution reservoir.
2. Turn Pressure Relief knob 1/4 turn.
3. Open the anti-syphon valve, if equipped
4. The discharge line is now depressurized.
5. If injection check valve is of higher elevation than pump head, disconnecting tubing at the injection check valve end will allow air to enter and cause solution to drain back to tank.

5.0 Liquid End Parts List

- 1 Flapper valve
- 2 Injection check valve body
- 3 Injection check valve spring
- 4 Check valve ball
- 5 Sealing ring
- 6 Cartridge valve
- 7 Cartridge valve o-ring
- 8 Cartridge valve washer
- 9 Valve seat
- 10 Clamp ring
- 11 Ferrule
- 12 Clamp sleeve
- 13 Tubing adapter
- 14 Coupling nut
- 15 Discharge tubing
- 16 Valve housing
- 17 Multi-function valve
- 18 High-viscosity spring
- 19 Liquifram
- 20 Pump head
- 21 Pump head screw
- 22 Suction tubing
- 23 Foot valve seat
- 24 Foot valve screen
- 25 High-viscosity valve seat
- 26 H.V. tubing clamp
- 27 H.V. suction tubing
- 28 H.V. Tubing x 1/2 NPT connector
- 29 Injection check valve assembly
- 30 Discharge valve assembly
- 31 Suction valve assembly
- 32 Pump head assembly
- 33 Foot valve assembly
- 34 Injection Seat PTFE
- 35 Ceramic Weight
- 36 Return Line
- 37 Cap ASM (Black Knob)
- 38 Cap ASM (Yellow Knob)
- 39 Multi-Function Valve Body
- 40 Nut Multi-Function Valve
- 41 Screw Multi-Function Valve
- 42 Return Line Coupling Nut
- 43 Adjustment Screw B/4-FV
- 44 Cap B/4-FV
- 45 Plug B/4-FV
- 46 Gasket B/4-FV
- 47 Small O-Ring B/4-FV
- 48 Large O-Ring B/4-FV

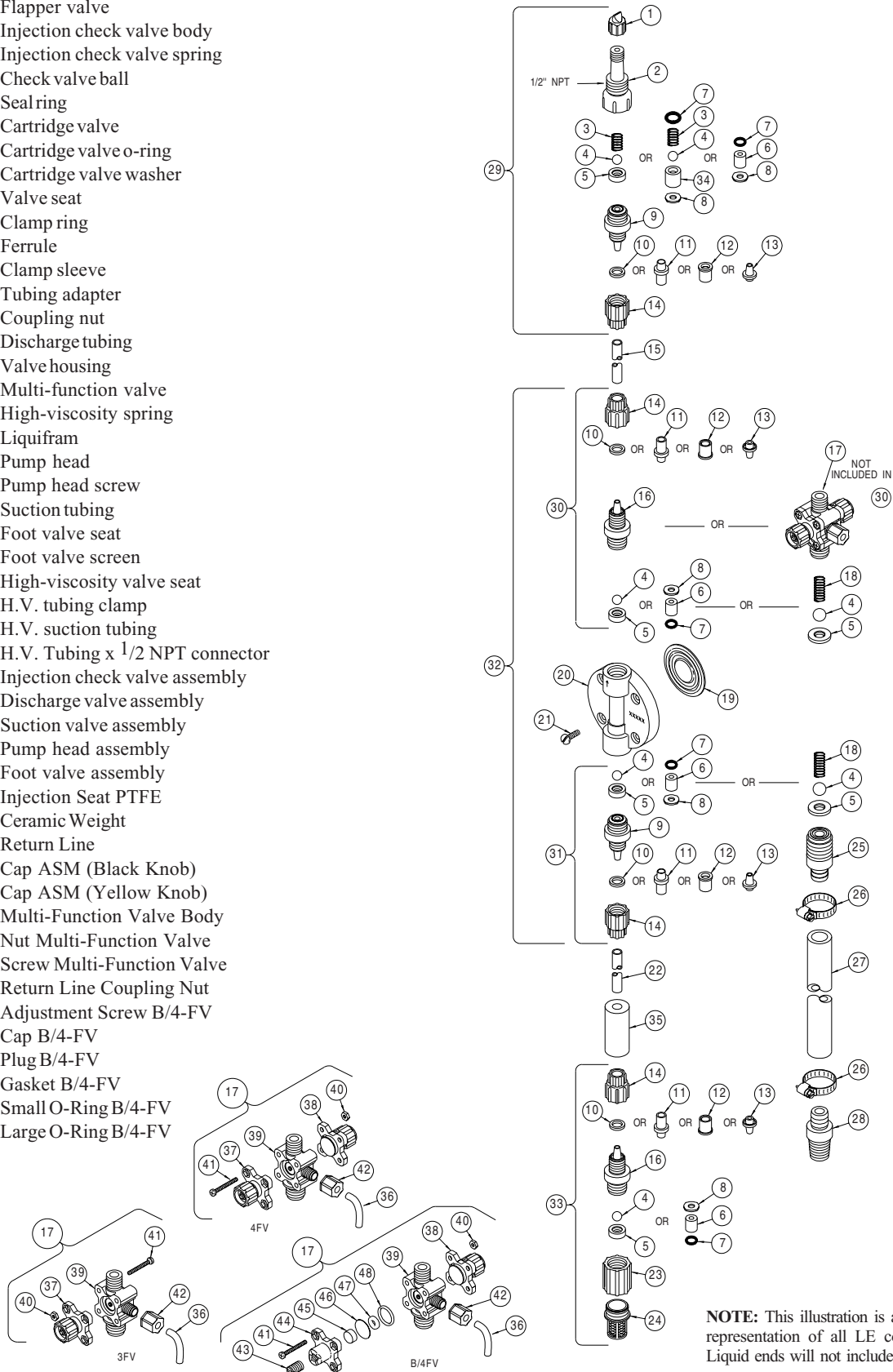

Start-Up/Priming for Pump Supplied with Multi-Function Valve

Read this entire section completely before proceeding.

When all precautionary steps have been taken, the pump is mounted, and the tubing is securely attached, you may now start priming the pump.

1. Plug in or switch the pump on.
2. While the pump is running, set the speed knob at 80% and the stroke knob at 100%.

If the pump is equipped with pressure control, turn fully clockwise.

3. 1/4 turn open the relief side (black knob) of the multi-function valve.
- 3A. **(Bleed 4FV only)** With screwdriver rotate bleed adjustment screw counter-clockwise 2 full turns. When solution begins to flow through translucent bleed return tubing, the pump is primed. Stop pump.
4. The suction tubing should begin to fill with solution from the tank.
5. A small amount of solution will begin to discharge out the return line of the multi-function valve. Once this happens, 1/4 turn or release the knob and **SHUT THE PUMP OFF.** (If pump is not equipped with an on/off switch, disconnect the power cord.)
6. The pump is now primed.
- 6A. **(Bleed 4FV only)**

- a. Start pump and let pump inject solution into the discharge line.
- b. Close the bleed adjustment screw by rotating it clockwise with a screwdriver.
- c. Now adjust the pump stroke length and/or speed (frequency) to a range approximately 25% higher than you would normally want for the process.
- d. Slowly rotate bleed adjustment screw counter-clockwise until just a small amount of solution begins to trickle down inside the bleed return tubing. A small amount of solution pumped back to the tank with each stroke of the pump will allow gas and air to escape without air or gas locking in the pump head.

NOTE: *If the pump does not self-prime, remove the multi-function valve on the discharge side of the pump head. Remove the check valve and pour water or solution into the port until the head is filled. Replace valve, then follow start-up/priming steps.*

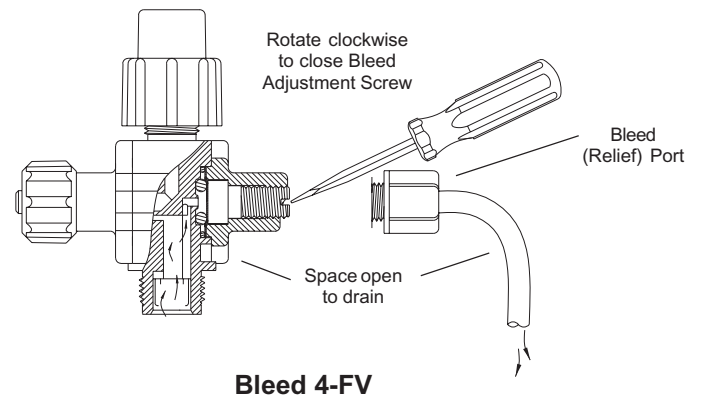
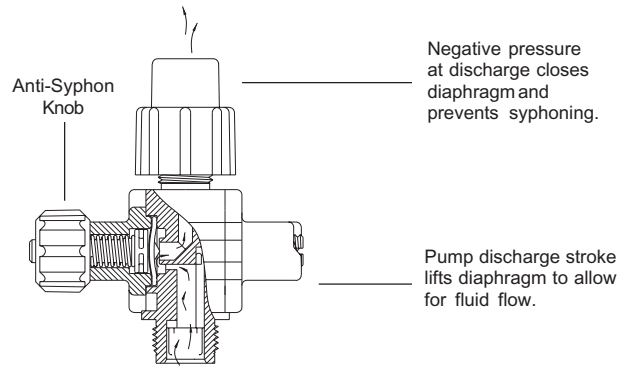

Start-Up/Priming without Multi-Function Valve

Read this entire section completely before proceeding.

When all precautionary steps have been taken, the pump is mounted, and the tubing is securely attached, you may now prime the pump.

1. Plug in or switch on the pump.
2. While the pump is running, set the speed knob at 80% and the stroke knob at 100%.

If the pump is equipped with pressure control, turn fully clockwise.

3. The suction tubing should begin to fill with solution from the tank.
4. Once the solution begins to exit the pump head on the discharge side, **SHUT THE PUMP OFF.** (If pump is not equipped with an on/off switch, disconnect the power cord).
5. The pump is now primed.

NOTE: *If the pump does not self-prime, remove the fitting on the discharge side of the pump head. Remove the ball and pour water or solution into the port until the head is filled. Replace valve, then follow start-up/priming steps.*