



ROYTRONIC® Series A Metering Pump

GENERAL

Chemical metering pumps shall be positive displacement, Liquifram™ type pumps. Relevant model codes are NSF Certified, UL/CUL or CE certified. Output volume shall be adjustable while pumps are in operation from zero to maximum capacity of:

Roytronic® Series A with FastPrime™ Liquid End		
A81, A71, A31, A11, A01	–	0.25 GPH (1.0 liters per hour)
A84, A74, A34, A14, A04	–	0.50 GPH (1.9 liters per hour)
A85, A75, A35, A15, A05	–	1.0 GPH (3.8 liters per hour)
A86, A76, A36, A16, A06	–	2.0 GPH (7.6 liters per hour)

Chemical metering pumps shall be capable, without a hydraulically backed diaphragm, of injecting solutions against pressures up to:

Roytronic® Series A with FastPrime™ Liquid End		
A81, A71, A31, A11, A01	–	250 psi (17.2 bar)
A84, A74, A34, A14, A04	–	250 psi (17.2 bar)
A85, A75, A35, A15, A05	–	110 psi (7.6 bar)
A86, A76, A36, A16, A06	–	50 psi (3.4 bar)

The FastPrime™ Liquid End² shall be equipped with a valve that allows for opening the head to atmospheric pressure to assist in pump priming. The AutoPrime™ Liquid End³ shall be equipped with a valve that allows for constant removal of vapors and gasses inherent in effervescent chemicals. The AutoPrime™ valve shall enable the pump to be primed automatically.

NOTE: AutoPrime™ liquid ends will recirculate a percentage of discharge material back to supply. Depending on application, output may be reduced up to 50%. Variables include supplier piping, stroke length and speed setting. Maximum pressure is 150 psi for AX1, AX4, 110 psi for AX5, 50 psi for AX6 models¹.

PUMP SPEED:

Model¹ AX1 – 120 strokes per minute max.

Model¹ AX4, AX5, AX6 – 240 strokes per minute max.

SERIES A0

The stroke frequency will be fixed. Stroke length shall be adjustable by a readily accessible dial knob located opposite the liquid handling end. A pulse indicator light will flash green when pumping. The pump shall be equipped with an on/off button.

SERIES A1

Adjustment shall be by means of readily accessible dial knobs, one for changing stroke length and the other for changing stroke frequency. Both knobs are to be located opposite the liquid handling end. A pulse indicator light will flash green when pumping. The pump shall be equipped with an on/off button.

Notes:

- Where X = control codes 0,1,3,7,8.
- Liquid End model codes ending with NI, SI, NM, SM, NU, SU, NP or SP.
- Liquid End model codes ending with AI, HI, AM, HM, AU, HU, AP or HP.
- Type 316 stainless steel or PTFE may be specified.

SERIES A3

The stroke frequency will be fixed. Stroke length shall be adjustable by means of readily accessible dial knob located opposite the liquid handling end. When in external mode, Series A3 units shall accept signals to pace the pump without the use of an electrical timer or internal timer. A pulse indicator light will flash green when pumping in internal mode, and yellow when pumping in external mode. The pump shall be equipped with an on/off button, a low level float switch input and a low level indicator light.

SERIES A7

Adjustment shall be by means of readily accessible dial knobs, one for changing stroke length and the other for changing stroke frequency. Both knobs are to be located opposite the liquid handling end. When in external mode, Series A7 units shall accept signals to pace the pump without the use of an electrical timer or internal timer. A pulse indicator light will flash green when pumping in internal mode, and yellow when pumping in external mode. The pump shall be equipped with an on/off button, a low level float switch input and a low level indicator light.

SERIES A8

Adjustment shall be by means of readily accessible dial knobs, one for changing stroke length and the other for changing stroke frequency. Both knobs are to be located opposite the liquid handling end. When in external mode, Series A8 units shall accept 4-20mA signal input for control of pump speed. A pulse indicator light will flash green when pumping in internal mode, and yellow when pumping in external mode. The pump shall be equipped with an on/off button, a low level float switch input and a low level indicator light.

DRIVE

The pump drive shall be totally enclosed with no exposed moving parts. Electronic pulser shall be supplied with quick connect terminals at least .110" wide (2.79 mm). Electronics shall be housed in chemical resistant enclosure at the rear of the pump for maximum protection against chemical spillage. Electrical power consumption shall not exceed 42 watts per hour under full speed and maximum pressure conditions. Pump weight shall not exceed 10 lbs (4.75 kg).

PRESSURE RELIEF

The LMI 4-Function Valve installed with a FastPrime™ or AutoPrime™ Liquid End is recommended to provide automatic pressure relief.

MATERIAL

Chemical metering pump housing shall be of chemically resistant glass fiber reinforced thermoplastic. All exposed fasteners shall be stainless steel. Chemical metering pump valves shall be ball type, with ceramic balls⁴. Valves shall be serviceable by replacing the cartridge valve assembly. Pump head shall be of transparent acrylic⁵ material capable of resisting the pumped chemical. Fittings and connections at pump head shall be PVC⁶.

CHECK VALVES AND TUBING

A total of 16 ft (4.8 m) of polyethylene tubing⁷ shall be provided per pump complete with compression connections. A foot valve with integral one piece strainer shall be provided for the suction line, and an injection check/back pressure valve with ½" NPT male connection for the injection point.

- PVDF, PVC, Polypropylene, or Type 316 stainless steel may be specified.
- PVDF, Polypropylene, or Type 316 stainless steel may be specified.
- 6 ft. (1.8 m) of vinyl suction tubing may be specified in place of polyethylene for the suction side only. 1/4" pipe thread may be specified.



201 Ivyland Road
Ivyland, PA 18974 USA
TEL: (215) 293-0401
FAX: (215) 293-0445
<http://www.lmipumps.com>

MOUNTING INFORMATION



FASTPRIME LIQUID ENDS

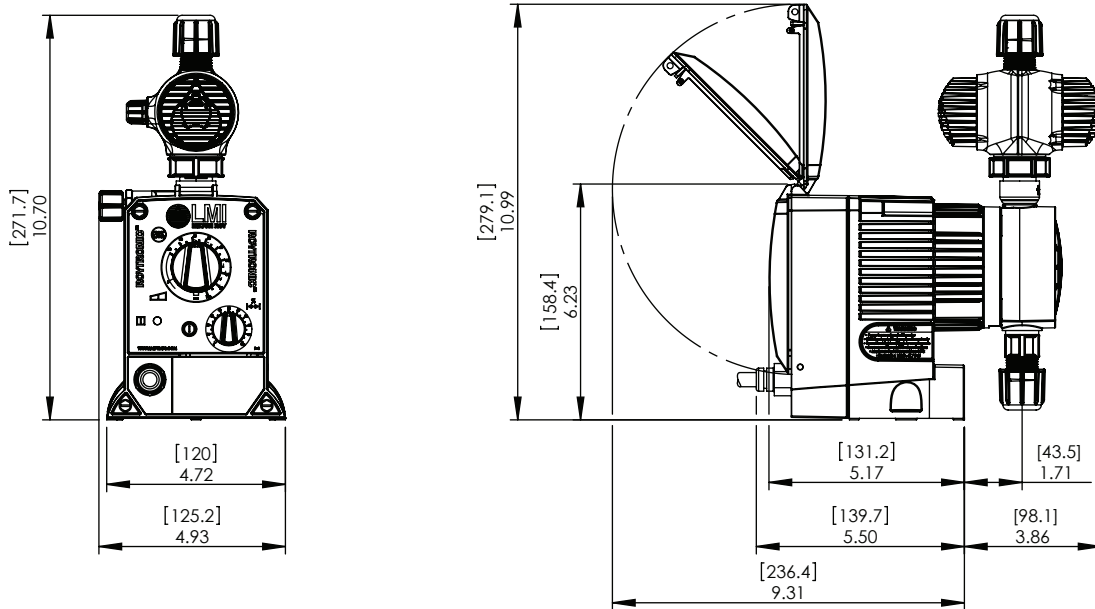

AUTOPRIME LIQUID ENDS

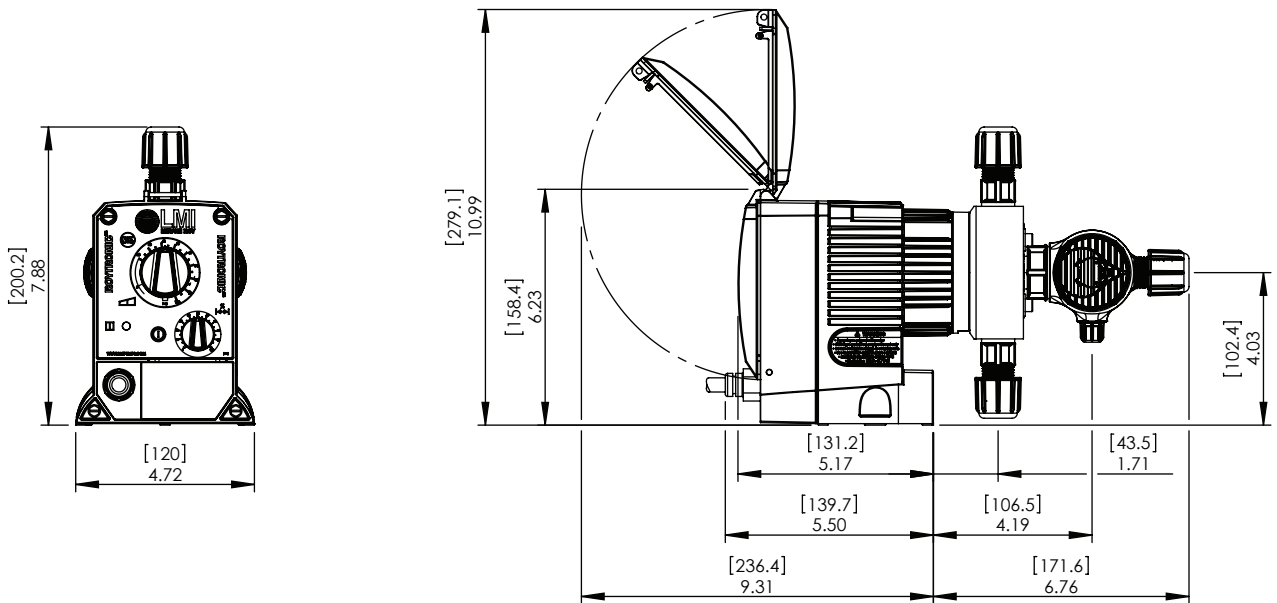

NOTE: ALL DIMENSIONS IN INCHES [MM]. DIMENSIONS SHOWN ARE FOR LARGEST LIQUID END. DIMENSIONS WILL VARY DEPENDING ON LIQUID END SELECTED.